

Visit the meeting website often for details on
Symposia, Exhibits, Biological and Physical Sciences Tutorials,
In-Week Intensive Workshops, Posters,
Sunday Short Courses and Pre-Meeting Congresses

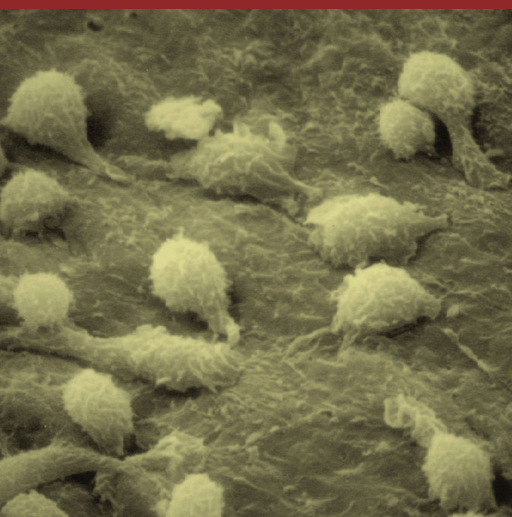

Monocytes (White Blood Cells) Adhering to the Inside Surface of an Artery as Part of an Inflammatory Reaction. W. Gray (Jay) Jerome, Vanderbilt University

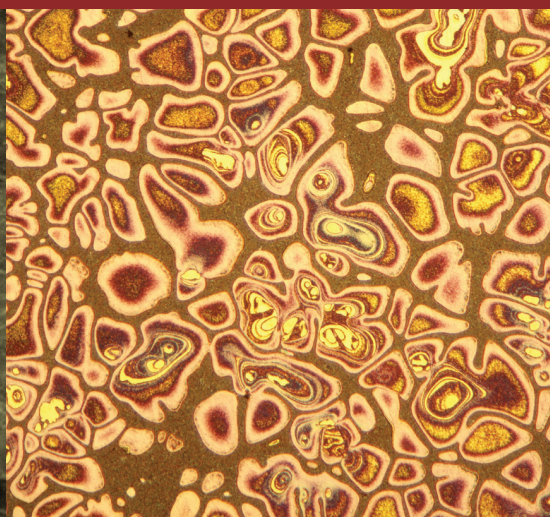

Cast A347 Alloy Made by Semi-solid Melting (Mert Fleming's Development) Weck's Reagent in Bright Field. George Vander Voort, Consultant (Struers Inc.)

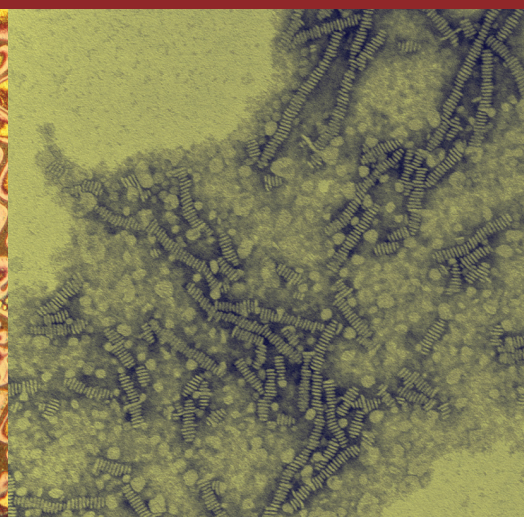

High Density Lipoprotein (HDL; the good cholesterol carrier) Stacking Together in Solution. W. Gray (Jay) Jerome, Vanderbilt University



M&M 2016
**MICROSCOPY &
MICROANALYSIS**
July 24-28, 2016 • Columbus, Ohio

<http://microscopy.org/MandM/2016>

Program Information | Information for Students | Meeting Awards | Exhibitor List & Floor Plan
Registration (opens February 2016) | Columbus Hotel Information (reservations available February 2016)



A WIDE VARIETY OF LEADING TECHNOLOGIES IN FIB-SEM WORKSTATIONS

GAIA3

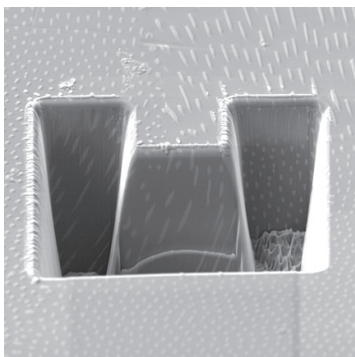

Low beam
energies
imaging

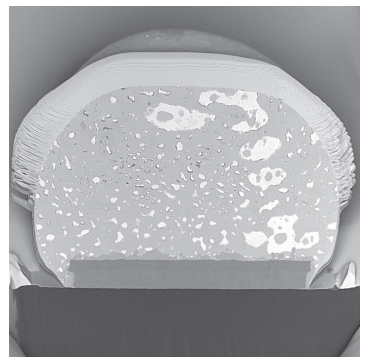
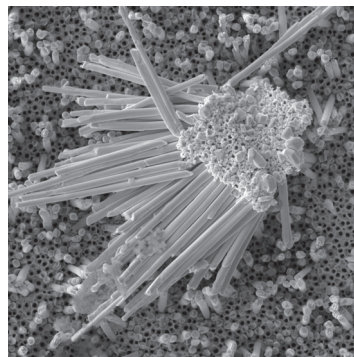

 **TESCAN USA**
TESCAN ORSAY HOLDING

765 Commonwealth Dr., Suite 101,
Warrendale, PA 15086
Tel: (724) 772 - 7433

www.tescan-usa.com

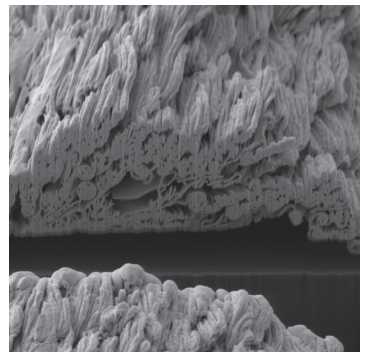
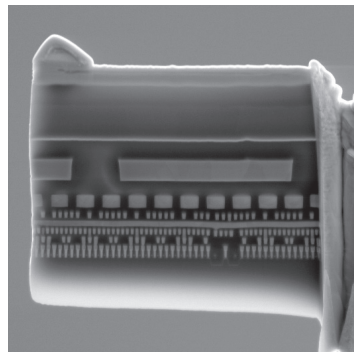



Precision, Speed, Stability

NANO-POSITIONING FOR MICROSCOPY & IMAGING

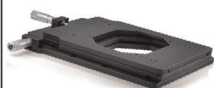

Manual Stage
25x25mm Travel



High-Speed Nanofocus
<1nm Resolution

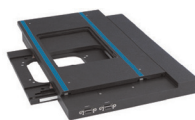

Ultra Stability
XY Piezo Motor Stage



XYZ Flexure Stage
<1nm Resolution

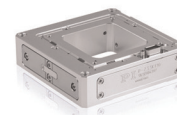

UHV Piezo Stage
0.1nm Resolution, XYZ

The Broadest and Deepest Portfolio of Precision Motion Technologies

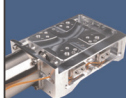

Vacuum Stages



Piezo Mechanics

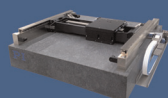

Air Bearings



Fiber Alignment



Hexapods

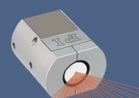

Beam Steering

Learn more ► www.pi-usa.us
508.832.3456
PI (Physik Instrumente)

INDEX TO ADVERTISERS

Bruker Nano GmbH	A7
Denton Vacuum	A5b
Diatome	Cover 3
Electron Microscopy Sciences, EMS	Cover 2, A1
FEI Company	A8
Hitachi	A11
JEOL	Cover 4, A12
PI (Physik Instrumente)	A15a
Scientific Instruments & Applications (SIA)	A5a
TESCAN	A14
ZEISS	A2

Incomparable...



...and still
innovating

DiATOME diamond knives

ultra 45° • cryo • histo
ultra 35° • histo jumbo
cryo immuno • ultra sonic
ultra AFM & cryo AFM
trimtool 20 • trimtool 45
trimtool 90

Over 40 years of development,
manufacturing, and customer service

DiATOME U.S.

P.O. Box 550 • 1560 Industry Rd. • Hatfield, Pa 19440
Tel: (215) 412-8390 • Fax: (215) 412-8450
email: sgkck@aol.com • www.emsdiasum.com

Free customer service

Sectioning tests with biological and material research specimens of all kinds. We send you the sections along with the surfaced sample, a report on the results obtained and a recommendation of a suitable knife. Complete discretion when working with proprietary samples.

Re-sharpening and reworking service

A re-sharpened Diatome diamond knife demonstrates the same high quality as a new knife. Even knives purchased in previous years can continue to be re-sharpened. The knives can be reworked into another type of knife for no extra charge, e.g. ultra to cryo or 45° to 35°.

Exchange service

Whenever you exchange a knife we offer you a new DiATOME knife at an advantageous price.

trimtool 90

Many requests from customers doing FIB cutting of biological and technical sample blocks have motivated us to relaunch the trim 90 blade:

Please contact us for more information.

DiATOME manip

Our new tool for an easy handling and mounting of section ribbons!

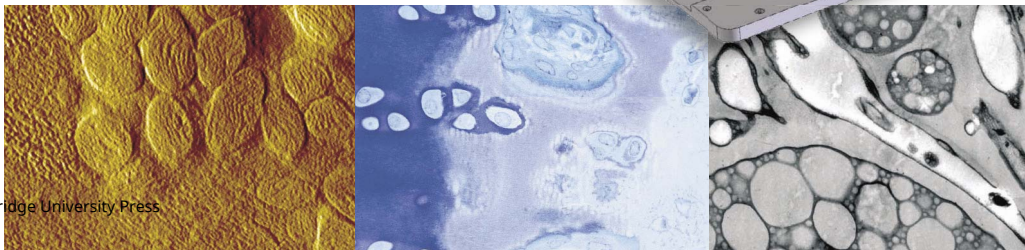
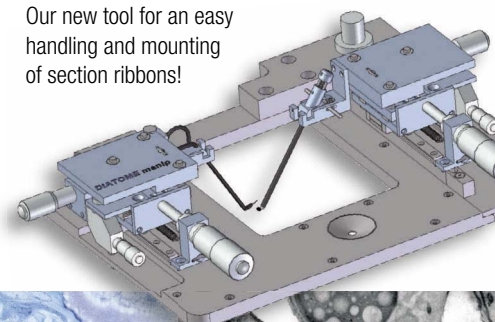

NO COMPROMISE

ATOMIC RESOLUTION + FAST ANALYSIS

The New "Go-To" TEM from JEOL

F2

- Cold FEG boosts probe current
- Fast 3D EDS with dual SDD
- Wide-field STEM-EELS spectrum imaging
- Push-button beam conditions
- Ultra-stable, ultra-fast

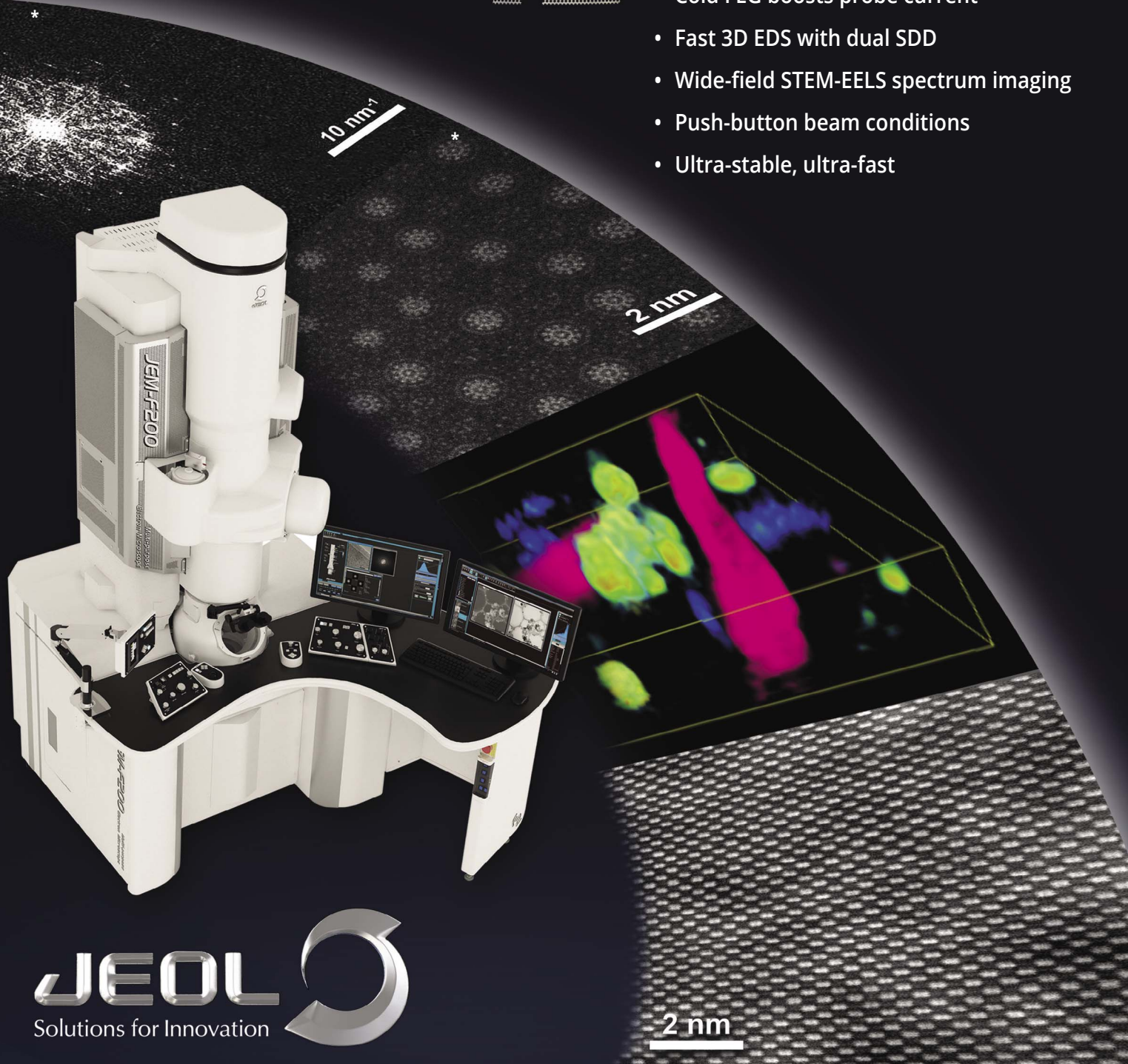

JEOL
Solutions for Innovation

www.jeolusa.com
salesinfo@jeol.com • 978-535-5900

Learn more at www.jeolusa.com/F2

*STEM-HAADF image of Quasicrystal • Courtesy of Professor Emeritus K. Hiraga - Tohoku University