

Prototyping industry 4.0: enhancing efficiency and productivity in small enterprises through iteration and low-cost solutions

Håkon Havsgård , Daniel Nygård Ege and Martin Steinert

Norwegian University of Science and Technology, Norway

 haakonhav@gmail.com

Abstract

This paper explores the implementation of Industry 4.0 technologies in Small Enterprises (SEs), focusing on the unique challenges they face. It presents four case studies demonstrating how low-cost, low-effort solutions can enhance efficiency and productivity in small companies. The solutions, developed in a local makerspace, address specific manufacturing challenges that lack affordable or existing off-the-shelf solutions. The paper highlights the value of iterative prototyping in implementing Industry 4.0 solutions and discusses how this approach can help SEs overcome adaptation challenges.

Keywords: prototyping, industry 4.0, small and medium size enterprise (SME), case study

1. Introduction

The need for digital transformation in Small and Medium sized Enterprises (SMEs) is significant, given their specific challenges and resource constraints. Incorporating Industry 4.0 technologies and principles into manufacturing can empower SMEs to surmount these hurdles by merging the digital and physical realms into cyber-physical systems, leading to heightened productivity and efficiency (Kumar et al., 2021). Several factors currently drive Industry 4.0 adoption in SMEs: new legislation and requirements, strategies to reduce costs and expedite a lower time-to-market, and a shortage of skilled personnel performing manual tasks (Contreras et al., 2018). However, despite a high level of adoption in larger corporations, limited awareness and understanding of the benefits (Schröder, 2016), substantial investment needs, risk aversion, and expertise gaps hinder the uptake of Industry 4.0 in SMEs (Stentoft et al., 2021). Furthermore, most Industry 4.0 technologies have been developed for or by large corporations, often overlooking the needs of SMEs (Masood and Sonntag, 2020). This misalignment renders many current technologies both too expensive and specialized for SMEs. Small enterprises (SEs), defined by the EU as companies with fewer than 50 employees and an annual turnover of less than 10 million euros, encounter even bigger obstacles. These challenges include limited access to digital infrastructure, skills shortages, risk aversion caused by small margins and larger consequences, and resistance to moving away from traditional work methods.

This paper details the design and initial testing of low-cost and low-fidelity prototypes that cater to specific digitization challenges faced by four different companies in the rural town of Oppdal, Norway, each employing between 2 and 50 people. Their location typically restricts access to national funding and larger scale digitalization initiatives linked with academic institutions. These businesses encounter specific manufacturing challenges that either lack off-the-shelf solutions or find them too costly to implement. The cases in this paper were selected based on their potential to illustrate different aspects and potentials of digitization, namely efficiency increase through semi-automation, waste reduction due to better production volume control, task simplification to decrease human error, and environmental

monitoring to enable process automation and/or optimization. The cases provide a detailed understanding of the challenges and opportunities associated with digital transformation in SEs. The four cases are: the creation of an automated stapler for slat wood panel production, a system to measure the area of irregularly shaped slate rock, an environment monitoring system for gourmet mushroom production, and a weighing and measuring system for custom ski cores. Prototyping and testing were performed by the authors, in close cooperation with key stakeholders, including management and production workers, in each company.

The paper aims to investigate the hypothesis that custom, low-cost, and low-fidelity prototypes can help overcome the specific digitization challenges faced by SEs, particularly in rural areas, potentially leading to improvements in efficiency, productivity, and performance. In doing so, the paper aims to answer the research question: "Can low-cost prototyping aid the adoption of new technologies and enable digital transformation in small companies?". We hypothesise that the proposed solutions, developed through an in-depth, case-by-case approach, are more likely to succeed in the context of SEs than off-the-shelf solutions, as they better address the unique needs, constraints, and risk aversion of these companies. Further, by performing in-depth investigations on a small number of companies to understand a complex issue in its real-life context (Yin, 1984) we inductively present suggestions of critical elements of successful low-cost Industry 4.0 implementation in SEs, in line with case-study research guidelines (Eisenhardt, 1989). With this paper we hope to provide valuable insights that can drive further research and development in this field of Industry 4.0 development and implementation in SEs. The remainder of the paper is structured as follows: A brief background section highlights a research gap, before the next sections present the 4 different case studies on the prototyping and testing of specific solutions for SEs. This is followed by a discussion that details key takeaways and value added in each case, the practical implications of this work, and directions for future research.

2. Background

Industry 4.0 integrates advanced digital technologies like the Internet of Things (IoT), Big Data Analytics, Additive Manufacturing, and Cloud Computing to enhance manufacturing processes, enabling more efficient production, and supply chain management (Jimeno-Morenila et al., 2021; Zheng et al., 2021). Recent studies also highlight Artificial Intelligence, 5G/6G and Quantum computing as technologies likely to drive Industry 4.0 development (Sigov et al., 2022). This digital transformation poses human-centered challenges, necessitating adaptations in organizational culture and strategy to fully leverage the potential of these technologies in a manufacturing environment.

Although most Industry 4.0 initiatives require substantial investment and adaptation (Ghobakhloo and Iranmanesh, 2021), instances of successful Industry 4.0 implementations with limited resources exist. These often involve retrofitting existing manufacturing equipment for monitoring usage and predictive maintenance, or process monitoring and real-time job tracking (Contreras et al., 2018; Jaspert et al., 2021; McFarlane et al., 2022). The primary traits of these initiatives are that they are incremental, low-cost, and SME-focused, unlike "traditional" Industry 4.0 implementations that strategically digitize the entire value chain and target larger companies (McFarlane et al., 2020). Yilmaz et al., (2023) used a similar approach to make a barcode scanner system costing just over 100 dollars enabling automated inventory tracking for a construction SME that would otherwise not have invested in such a system due to cost. These exemplified cases have in common that they utilize off-the-shelf solutions (OTS). Integrating OTS components with Industry 4.0 methods have been shown to trigger business model changes that impact value creation and capture (Müller et al., 2018), enhancing productivity and quality (Schneider, 2018), and ensuring sustainability while enhancing value creation (Stock and Seliger, 2016).

This research, however, does not address how SEs can benefit from digitization when off-the-shelf solutions don't exist.

The agile nature of prototyping presents an intriguing strategy for digitizing and improving manufacturing capabilities in SEs. Prototyping, by its very design, allows for iterative development and testing, enabling small businesses to explore Industry 4.0 technologies without committing extensive resources upfront, and can simplify development of new solutions with focused purposes to test core assumptions of eventual designs (Lim et al., 2008), by using prototypes for continuous learning (Lauff

et al., 2018). Prototypes can accommodate changing or emerging requirements (Kriesi et al., 2016), help discover unknown unknowns that a new system must accommodate (Steinert and Leifer, 2012), elicit the tacit knowledge of the workers the system will be assisting (Ege et al., 2020) and facilitate communicating (Buchenau and Suri, 2000). This method stands in contrast to the large-scale, capital-intensive implementations that have traditionally characterized Industry 4.0 rollouts, placing them beyond the reach of smaller firms.

3. Case studies

The following sections contain a description of each case study with the identified need, prototyping and results of initial testing of each proposed solution.

3.1. Case study 1: An automated stapler for acoustic slat panel production

The subject of the first case study is a small producer of acoustic slat wood panels, catering to both consumer and professional markets. The consumer offerings are standardized in size and material options, while the professional range is tailored to specific project requirements. Each panel comprises wooden slats affixed to a synthetic backplate through a combination of glue and staples. The production process involves manually positioning the slats within a jig, followed by the placement of a synthetic felt backplate, which is then stapled from behind. This hand-operated assembly method has been identified as laborious and repetitive, contributing to significant physical strain on the workers, particularly affecting their backs and shoulders. Despite the availability of mechanized solutions for panel assembly, the company's limited financial capacity and concerns over market volatility have precluded the investment in such technology. Consequently, the company needs a cost-effective, adaptable solution to enhance productivity without compromising the ability to accommodate varying sizes and types of panels.

An initial small-scale prototype was built to identify and assess necessary components, requirements, and software. A combination of aluminium extrusions and 3D printed carriages powered by stepper motors, with a pen serving as a stand-in for the staple gun (Figure 1a), constituted the first prototype. Through iterative refinements, the design evolved to meet the emerging demands and incorporate new insights gained during the development process. One of the key insights revealed during prototype testing was that the adjustable z-axis of the system, that had initially moved the pen up and down, was unnecessary, as the backing plate was smooth enough that the staple gun could simply glide across it without having to move up or down. This change from the initial requirements, that were defined prior to prototyping, decreased the complexity, and cost of the system.

The culmination of prototyping activities is a final prototype consisting of aluminium extrusions along the workbench where a jig was mounted. A mobile carriage, equipped with the stapling gun, traverses these extrusions, powered by two stepper motors via belts (Figure 1b). The actuation of the staple gun is achieved through a servo motor. Figure 1c shows a block diagram of the entire system.

Initial evaluations of the automated system have showed several benefits, including increased operational efficiency, better product quality with less risk of human error, and improved labour conditions. The automation of stapling allows for concurrent task execution, in which the worker is able to prepare the next panel during stapling. A benchmark test of the system with a comparison to the current manufacturing process can be found elsewhere in literature (Kildal et al., 2024). It shows that implementing the system as is, has the potential to decrease the production rate of acoustic slat panels by more than 40%, a significant decrease when keeping in mind that the system has a material cost of less than 400 euros. Moreover, the machine demonstrates consistency, completing nearly identical operational cycles. This attribute of consistent performance bolsters the reliability of the production process and fortifies planning capabilities. The precision in nail placement reduces material waste and increases the durability of the panels by preventing wood splitting, a common issue in manual assembly that leads to rework and discarded products.

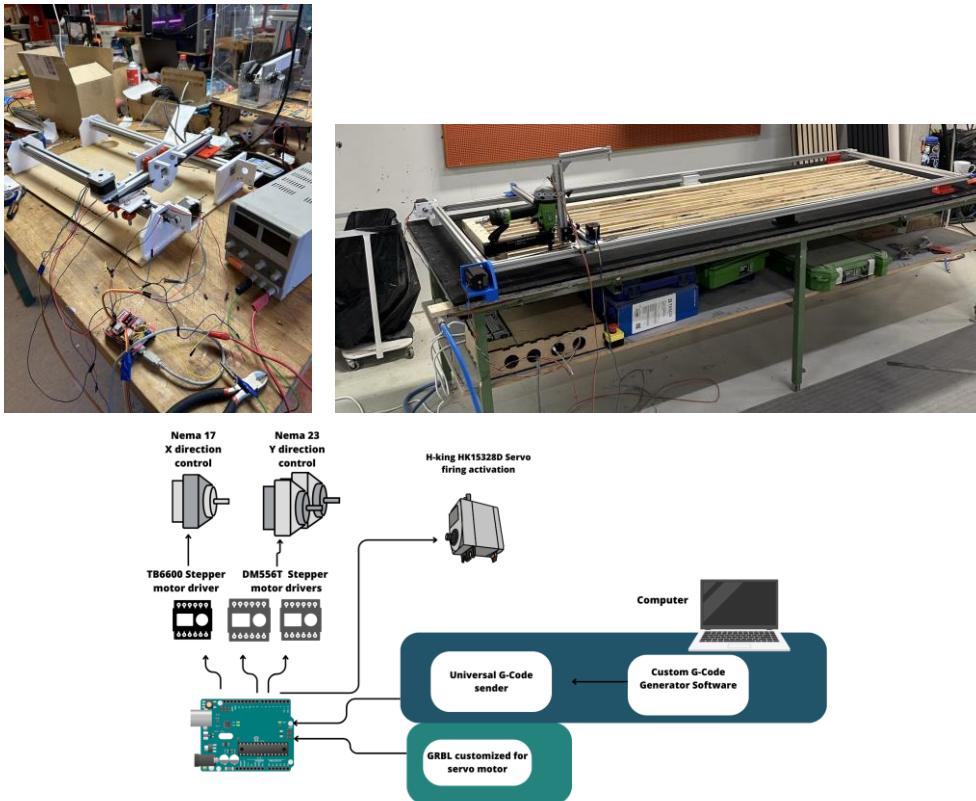

Figure 1. (a) Scaled down prototype with a pen serving as the tool; (b) Final prototype; (c) Block-diagram of the machine system

3.2. Case study 2: Measuring the size of irregularly shaped slate rock

The second case study examines the production of slate rock products. Production and processing are adjacent to a slate quarry, where local stone cutters craft a variety of slate items ranging from flagstone to machine-cut and polished tiles. The task of splitting and shaping slate blocks into varied products is intricate and sensitive, making it challenging to fully automate, particularly considering financial constraints. The company, selling slate by area, faces difficulties in measuring the quantity of slate packed on each pallet, with irregularly shaped flagstones presenting a specific challenge. The variation in thickness, both within individual slates and between different pieces, renders weight measurement ineffective for determining quantity. To guarantee customer satisfaction, the company habitually overloads pallets, a practice derived from trial and error to avoid complaints of underfilled orders, leading to waste. An accurate system to measure irregularly shaped slates before packing could notably reduce this waste and provide data on the extent of over-delivery.

An initial prototype system utilizing laser-cut mock slabs and a computer vision system (OpenCV (Bradski, 2000)), was devised to ascertain if it could accurately gauge slab areas of unregularly shaped flagstone. It utilizes a camera phone situated above the mock slabs (Figure 2a), sending images to a computer running OpenCV, allowing for the identification of the most promising algorithms. Tests revealed that the most effective method in essence entailed determining the slab contours and counting the enclosed pixels, and thus was selected for further testing. To increase the system's accuracy, calibration tools were iteratively implemented throughout the process to account for different cameras and test environments.

Initial field tests on a black conveyor belt highlighted the grey slabs' contrast, aiding measurement accuracy (Figure 2b and c). To test the accuracy of the system and circumvent operational challenges, a separate measuring station was established next to the conveyor belt (Figure 2d), with a black fabric backdrop and an overhead camera for slab imaging before packing. Calibration was performed using laser-cut plates of known dimensions and confirmed the system's precision with an error under 1%. The system was programmed to keep track of the total packaged area and notify the operator when the pallet

approached its predetermined capacity of 15 square meters. In order to assess the potential and implication of implementation, a finished packed pallet of flagstone was measured using the prototype system. The pallet was intended to contain 15 square meters, but the system revealed an area of 18.82 square meters – nearly 26% over the intended area that is in practice a finished product given away as the company only charges the 15 square meters.

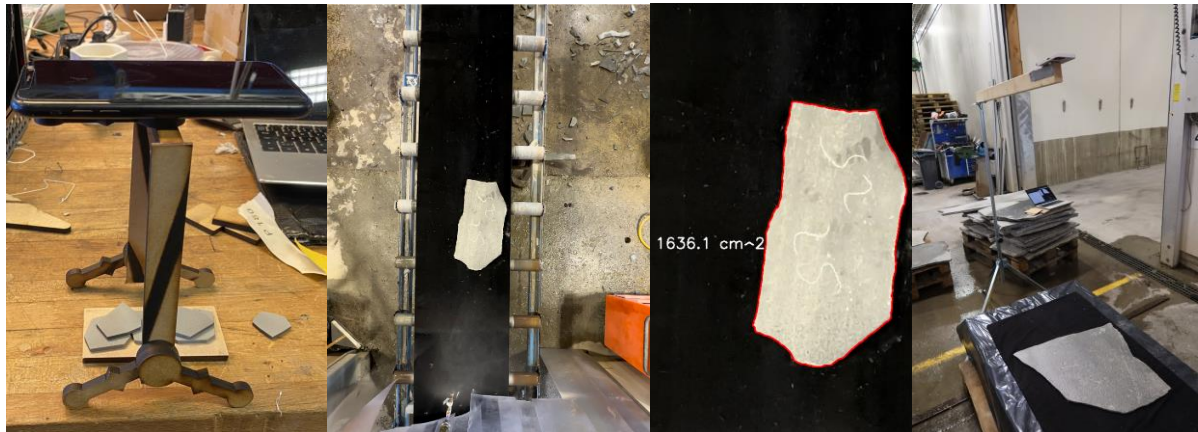

Figure 2. (a) Initial prototype setup; (b) Raw input from camera; (c) Computer vision result; (d) Physical test setup

3.3. Case study 3: Simplifying density measurement of custom wooden ski cores

The third case study investigates a small-scale ski manufacturer that specializes in the production of bespoke touring and downhill skis. A critical step in their production, and what separates them from large-scale manufacturers, involves the meticulous measurement and weighing of ski cores—the primary wooden structure within the ski—to accurately gauge their density. Matching the density of the cores for each pair is paramount to ensuring uniformity in performance characteristics. The density is also a main factor when deciding the appropriate shape and width of each ski pair. Given the handmade nature of these cores and the inherent variability in wood density, the precision in determining each core's density is vital for shaping the ski and achieving optimal performance. Traditionally, the process has been laborious and prone to human error, involving manual measurements of each core's dimensions, followed by weighing, and then referencing a density chart based on these inputs. This method not only consumes significant time but also limits production efficiency, with the task entrusted to a single experienced worker, highlighting the need for a more streamlined approach.

To address these challenges, a novel prototype was developed (as shown in Figure 3), employing a load cell for weight measurement and a linear potentiometer linked to a tension spring for determining the core's width. This setup, supported on a platform designed to hold the ski core, allows for the input of the core's length and thickness via two knobs. An Arduino microcontroller processes the sensor data to calculate the core's density, with results displayed on an OLED screen.

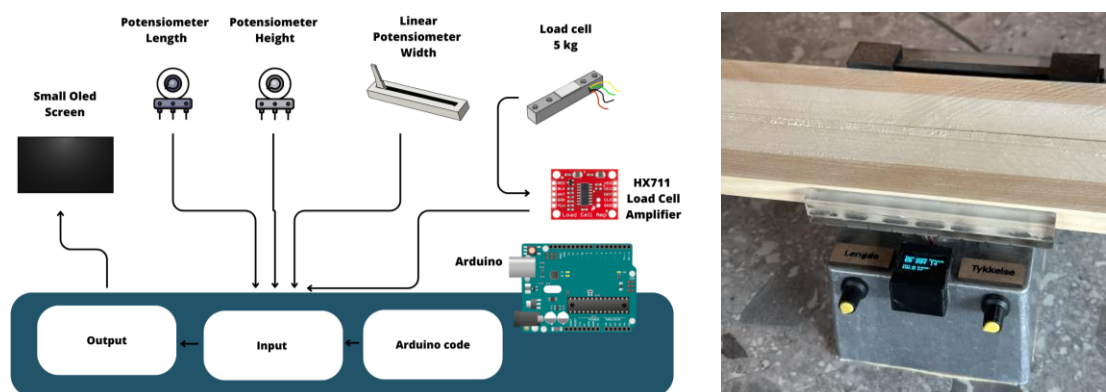

Figure 3. a) Block diagram wooden ski core measurement system; (b) Prototype solution

3.4. Case study 4: Environment monitoring system for gourmet mushroom production

The final case study explores how a small-scale gourmet mushroom producer can enhance and optimize its cultivation processes through precise environmental control. At present time the producer is relying on qualitative assessments and intuition for controlling the humidity and temperature where mushrooms are grown, lacking both precision and knowledge on optimal environment characteristics. To address the lack of data and control over the production environment, an Arduino Nano 33 IoT based monitoring system was prototyped. The system, illustrated in Figure 4a, contains sensors able to measure CO₂ concentration, humidity, light conditions, ambient temperature, and temperature within buckets where mushrooms were growing. The Arduino board offers plug-and-play Wi-Fi capabilities, which allowed real-time data monitoring and cloud connectivity of the system. The monitoring system collected data on all critical environmental parameters (Figure 4b), aiming to improve understanding of optimal growth conditions and inform decisions to optimize yield. By using the system and recording production volumes the company could learn what the optimum environment was and how to control it.

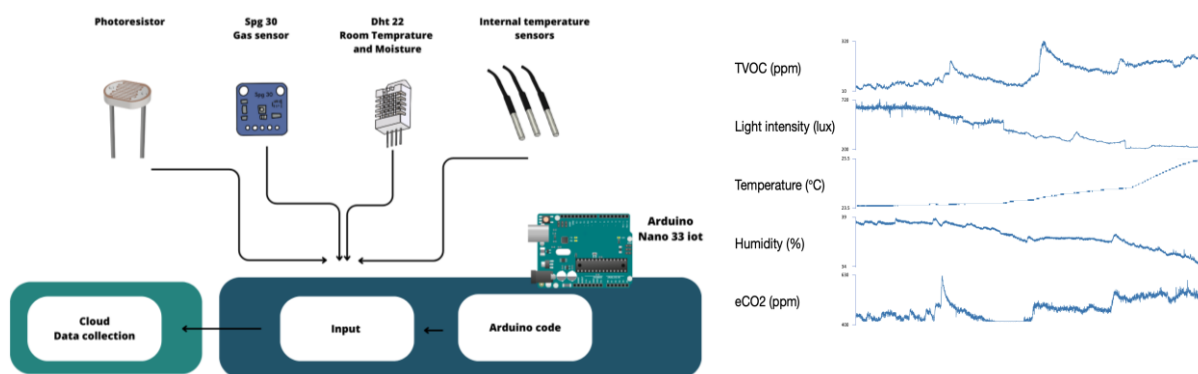

Figure 4. (a) Block diagram of gourmet mushroom measurement system; (b) Example data produced by the monitoring system

4. Discussion

The essence of the presented case studies lies not in offering complete, industrial solutions, but in demonstrating the potential of low-cost prototyping efforts to inform the decision on whether to advance with technological integration to initiate digital transformation. These prototypes and case studies show that low-cost prototyping might aid the adoption of new technologies and enable digital transformation in small companies. They also appear to support the hypothesis that solutions developed through an in-depth, case-by case approach, characterized by iterative development, are more likely to succeed in the context of SEs than off-the-shelf solutions, by better addressing the unique needs and constraints of these enterprises. The following section presents key takeaways from each case to underscore this argument.

4.1. Key takeaways and value added from case studies

The case studies and feedback from key stakeholder in the companies highlight several key benefits of low-cost prototyping to initiate digital transformation. Firstly, the presented examples provide a low-risk entry point for small companies to explore digitization. It fostered skill transfer, equipping workers and management with a better understanding of the potential applications of new technologies and sparked interest in further exploration, and importantly, did so without requiring significant investments. The following key takeaways and value were created from each case study:

Case 1: The automated nail gun prototype brought forth significant improvements in efficiency by potentially decreasing the production time by more than 40%, improved process reliability by reducing the chance of error during production and has the potential of improving worker well-being by removing a straining procedure. Importantly, it also catalysed discussions among staff and developers about

further integration into the factory workflow, highlighting the potential for full-scale operational transformation. The system's ability of repeated production time could potentially leading to better production planning capabilities. Being a machine, as opposed to a worker, the prototype can also gather data that could inform algorithms that improve production efficiency and planning.

Case 2: As a pilot implementation, the slate measurement system demonstrated technical viability and the potential for the digital transformation of packing facilities. Beyond its ability to accurately measure slates, the system offers the prospect of providing accurate production data, which could markedly enhance production planning and operational efficiency, thereby enabling the adoption of Industry 4.0 principles. The findings presented in this paper highlight the significant savings potential of this technology. Consequently, the company has decided to proceed with its development, thus highlighting the potential of using prototypes to mature digitization decision and uncover a viable technological solution at low risk. Currently, efforts are focused on developing a comprehensive system capable of measuring each slate on the conveyor belt, categorizing it correctly into one of around 20 product lines based on thickness and are, and ensuring it is packed onto the appropriate pallet for full-scale implementation.

Case 3: The ski core density measurement overhaul exemplifies streamlining and error reduction in a critical production process. By eliminating the need for extensive density tables and accommodating new ski dimensions effortlessly, the system showcased the potential for significant time and resource savings. Following the implementation of the system, the ski producer plans to add a new line of skis with different sizes than current lines, that would require more than 60 new density tables to be printed and used during manufacturing. The new system on the other hand accommodates these new dimensions without extra effort.

Case 4: The gourmet mushroom production case illustrates the foundational role of data collection in transitioning towards Industry 4.0. By implementing an affordable, bespoke monitoring system for mushroom cultivation, the producer not only gains insights into optimal growth conditions but also enables broader digital transformation. The approach democratizes access to data analytics, enabling even small-scale operations to leverage technological advancements for improved outcomes.

The role of user engagement in these case studies is paramount, offering insights into the practical implications of integrating new technologies into existing workflows. Active involvement of workers and management in the prototyping process ensures that the developed solutions are not only technically viable but also practically applicable, addressing real-world challenges encountered in daily operations. As employees witness and contribute to the incremental improvements and successes of prototype development, their buy-in and enthusiasm for change are likely to increase, thereby easing the transition towards more advanced manufacturing systems. It also helped alleviate the scepticism of workers that for different reasons either disliked the idea of change or didn't believe that new solutions could improve their daily work. For instance, in Case 1, the dialogue initiated between employees and developers regarding the automated nail gun prototype led to insights into how the prototype could be integrated into existing workflows, highlighting areas for further refinement and potential expansion of its application. This collaborative approach provided developers with the information needed to solve both the technical and practical needs of the workers, enhancing the likelihood of successful adoption and utilization. This participatory approach to implementing Industry 4.0 could potentially help address the skill shortages often encountered by SEs, as it serves as an on-the-job training mechanism that upskills the workforce while new systems are being developed and refined. Similarly, in Case 3, the involvement of ski production workers in testing and providing feedback on the ski core density measurement system allowed for adjustments that significantly increased the prototype's utility. Workers' insights into the operational challenges of ski production, such as the need for dust shielding and accommodating a wider range of ski models, were crucial in tailoring the system to meet the company's specific needs. This engagement not only improved the prototype's design but also built a sense of shared accomplishment and commitment to the project's success within the company.

Access to a local makerspace has proven instrumental in this context, providing a collaborative environment where ideas can be rapidly prototyped, tested, and refined. Makerspaces offer the resources and equipment needed to bridge the gap between concept and reality, enabling experimentation and iterative development of technological solutions. Having these capabilities in close vicinity to the companies meant that iterations and alterations could be performed quickly, to adapt to new learnings and insights gathered during testing or in conversation with users.

In each case, prototyping emerges as a critical step in the path toward digital transformation, allowing companies to explore the feasibility and impact of technological solutions in a controlled, cost-effective manner. These prototypes serve as proofs of concept, demonstrating how digital technologies can be tailored to meet the specific needs of SEs. They enabled concept validation and adaptation to operational feedback at an early enough stage that it could be changed- something that might not have happened if the companies were to invest in equipment made for them by others. Furthermore, this approach mitigates risk for companies considering further investment in developing these solutions. It involves the iteration of multiple concepts, with the most promising selected for further development. For example, in case 2, the technology is validated early, minimizing the risk of investing significant time and money in a solution that ultimately proves unfeasible. Similarly, case 1 allows for the assessment of potential time savings from implementing a staple gun robot, thereby providing a clearer understanding of the trade-offs between discontinuing the project and advancing it. This strategic method ensures resources are allocated efficiently, optimizing the decision-making process regarding technological investments. Simultaneously, prototyping provided valuable insights into the operational changes required for their successful implementation. Through this process, SEs are equipped to make informed decisions about pursuing further development and integration of these technologies, thereby laying the groundwork for broader adoption and more significant impacts in the future.

4.2. Practical implications

The discussion around prototyping digital solutions for SEs raises important questions about companies' internal capabilities and the necessity of collaboration. The work presented in this paper relied on the involvement with an academic institution to undertake the development project, implying that there is still a critical need to address the sustainability of such initiatives within the companies themselves. Solutions could be to foster either in-house or locally accessible prototyping capabilities, such as through rural makerspaces with access to competent personnel but would likely necessitate external funding. Moreover, it is important to clarify that our study does not suggest that SEs should independently undertake the development of these solutions without external support. Instead, we emphasize the value of the prototyping approach we have implemented as a viable method for developing solutions specifically tailored to the unique challenges and needs of SEs.

One of the main issues when trying to enable digital transformation in SEs is that they might not know themselves what they need. For instance, the company from case 1 initially presented their idea of how to automate their production by buying a universal robot arm that they envisioned could perform all the manual tasks of assembling the acoustic panels. The company neither considered the practical implications of installing or working with a robot, nor its cost or the fact that no one had the knowledge on how to operate or maintain such a robot. They were also unaware of any potential efficiency gain from implementing it. This example emphasizes the need for a more grounded approach to identifying and developing technological solutions, especially for SEs, where the value of practical, scalable solutions is recognized over high-cost, complex systems.

It is worth noting that this paper solely investigates solutions at a prototype level- meaning that results, although promising, could improve even more given refinement and optimization. Future work should aim to validate these findings across a larger sample of SEs and in different contexts and include more case studies to substantiate and expand upon initial findings. Moreover, expanding the research to encompass long-term studies based on quantitative data could offer insights into the enduring effects of these technological adoptions, evaluating how SEs evolve post-implementation and the sustained relevance of the prototypes. In-depth exploration into the mechanisms for scaling these prototyping approaches to benefit a larger segment of the industry is also crucial. Investigating how these practices

can be adapted and applied in different contexts, particularly in rural and under-resourced areas, can offer pathways to more inclusive digital transformations.

4.3. Limitations

Although the findings presented in this paper are promising, the research is based on a select number of case studies, which, while diverse, may not fully represent the broad spectrum of challenges and opportunities faced by SEs across different industries and regions. Further, the involvement with academic institutions played a significant role in the development of prototypes, highlighting a dependency that may not be feasible for SEs and that needs to be addressed in future research. The findings in the paper are based on initial tests of prototypes that indicate the possibility for improvements rather than providing quantitative data on the actual impact. Measuring the long-term impact of the solutions is therefore subject to future work. Based on these limitations, the broader implications of these findings need to be interpreted with caution until further research is conducted.

5. Conclusion

This study suggests that customized, low-cost Industry 4.0 solutions can help address specific challenges faced by Small Enterprises (SEs), particularly those in rural areas. Through a case-by-case approach involving prototyping and iterative development, these solutions were found to improve operational efficiency, product quality, and foster skill transfer. However, given the limited number of case studies, these promising results should be interpreted with caution, requiring further research to confirm and generalize these findings. Future work should include more case studies and explore aspects like long-term impacts or scaling strategies. This research presents a promising direction for Industry 4.0 implementation in SEs, potentially enabling more inclusive and sustainable digital transformations across the sector, especially in rural and under resourced areas.

Acknowledgement

This research is supported by the Research Council of Norway (grant number 321386).

References

- Bradski, G., 2000. The OpenCV Library. *Dr. Dobb's Journal of Software Tools*.
- Buchenau, M., Suri, J.F., 2000. Experience prototyping, in: *Proceedings of the Conference on Designing Interactive Systems Processes, Practices, Methods, and Techniques - DIS '00*. Presented at the the conference, ACM Press, New York City, New York, United States, pp. 424–433. <https://doi.org/10.1145/347642.347802>
- Contreras Pérez, J.D., Cano Buitrón, R.E., García Melo, J.I., 2018. Methodology for the Retrofitting of Manufacturing Resources for Migration of SME Towards Industry 4.0, in: Florez, H., Diaz, C., Chavarriaga, J. (Eds.), *Applied Informatics, Communications in Computer and Information Science*. Springer International Publishing, Cham, pp. 337–351. https://doi.org/10.1007/978-3-030-01535-0_25
- Ege, D., Lilleløyken, O., Auflem, M., Steinert, M., 2020. Dealing with Ecological Validity and User Needs when Developing Simulation Based Training Equipment – Case Study of a Medical Palpation Task Trainer. *Procedia CIRP* 91, 722–727. <https://doi.org/10.1016/j.procir.2020.03.116>
- Eisenhardt, K.M., 1989. Building Theories from Case Study Research. *The Academy of Management Review* 14, 532–550. <https://doi.org/10.2307/258557>
- Ghobakhloo, M., Iranmanesh, M., 2021. Digital transformation success under Industry 4.0: a strategic guideline for manufacturing SMEs. *Journal of Manufacturing Technology Management* 32, 1533–1556. <https://doi.org/10.1108/JMTM-11-2020-0455>
- Jaspers, D., Ebel, M., Eckhardt, A., Poepplbuss, J., 2021. Smart retrofitting in manufacturing: A systematic review. *Journal of Cleaner Production* 312, 127555. <https://doi.org/10.1016/j.jclepro.2021.127555>
- Jimeno-Morenilla, A., Azariadis, P., Molina-Carmona, R., Kyrtzi, S., Moulianitis, V., 2021. Technology enablers for the implementation of Industry 4.0 to traditional manufacturing sectors: A review. *Computers in Industry* 125, 103390. <https://doi.org/10.1016/j.compind.2020.103390>
- Kriesi, C., Blindheim, J., Bjelland, Ø., Steinert, M., 2016. Creating Dynamic Requirements through Iteratively Prototyping Critical Functionalities. *Procedia CIRP*, 26th CIRP Design Conference 50, 790–795. <https://doi.org/10.1016/j.procir.2016.04.122>

- Kumar, P., Bhamu, J., Sangwan, K.S., 2021. Analysis of Barriers to Industry 4.0 adoption in Manufacturing Organizations: an ISM Approach. *Procedia CIRP*, The 28th CIRP Conference on Life Cycle Engineering, March 10 – 12, 2021, Jaipur, India 98, 85–90. <https://doi.org/10.1016/j.procir.2021.01.010>
- Lauff, C., Kotys-Schwartz, D., Rentschler, M., 2018. What is a Prototype? What are the Roles of Prototypes in Companies? *Journal of Mechanical Design* 140. <https://doi.org/10.1115/1.4039340>
- Lim, Y.-K., Stolterman, E., Tenenbergh, J., 2008. The anatomy of prototypes: Prototypes as filters, prototypes as manifestations of design ideas. *ACM Trans. Comput.-Hum. Interact.* 15, 7:1-7:27. <https://doi.org/10.1145/1375761.1375762>
- Masood, T., Sonntag, P., 2020. Industry 4.0: Adoption challenges and benefits for SMEs. *Computers in Industry* 121, 103261. <https://doi.org/10.1016/j.compind.2020.103261>
- McFarlane, D., Ratchev, S., de Silva, L., Hawkrigde, G., Schönfuß, B., Angulo, G.T., 2022. Digitalisation for SME Manufacturers: A Framework and a Low-Cost Approach. *IFAC-PapersOnLine*, 14th IFAC Workshop on Intelligent Manufacturing Systems IMS 2022 55, 414–419. <https://doi.org/10.1016/j.ifacol.2022.04.229>
- McFarlane, D., Ratchev, S., Thorne, A., Parlikad, A.K., de Silva, L., Schönfuß, B., Hawkrigde, G., Terrazas, G., Tlegenov, Y., 2020. Digital Manufacturing on a Shoestring: Low Cost Digital Solutions for SMEs, in: Borangiu, T., Trentesaux, D., Leitão, P., Giret Boggino, A., Botti, V. (Eds.), *Service Oriented, Holonic and Multi-Agent Manufacturing Systems for Industry of the Future*, Studies in Computational Intelligence. Springer International Publishing, Cham, pp. 40–51. https://doi.org/10.1007/978-3-030-27477-1_4
- Müller, J.M., Buliga, O., Voigt, K.-I., 2018. Fortune favors the prepared: How SMEs approach business model innovations in Industry 4.0. *Technological Forecasting and Social Change* 132, 2–17. <https://doi.org/10.1016/j.techfore.2017.12.019>
- Schneider, P., 2018. Managerial challenges of Industry 4.0: an empirically backed research agenda for a nascent field. *Review of Managerial Science* 12, 803–848. <https://doi.org/10.1007/S11846-018-0283-2>
- Schröder, C., 2016. The Challenges of Industry 4.0 for Small and Medium-sized Enterprises, Friedrich-Ebert-Stiftung, Abteilung Wirtschafts- und Sozialpolitik, gute gesellschaft – soziale demokratie # 2017 plus.
- Sigov, A., Ratkin, L., Ivanov, L.A., Xu, L.D., 2022. Emerging Enabling Technologies for Industry 4.0 and Beyond. *Inf Syst Front.* <https://doi.org/10.1007/s10796-021-10213-w>
- Steinert, M., Leifer, L.J., 2012. ‘Finding One’s Way’: Re-Discovering a Hunter-Gatherer Model based on Wayfaring. *International Journal of Engineering Education* 28, 251.
- Stentoft, J., Adsbøll Wickstrøm, K., Philipsen, K., Haug, A., 2021. Drivers and barriers for Industry 4.0 readiness and practice: empirical evidence from small and medium-sized manufacturers. *Production Planning & Control* 32, 811–828. <https://doi.org/10.1080/09537287.2020.1768318>
- Stock, T., Seliger, G., 2016. Opportunities of Sustainable Manufacturing in Industry 4.0. *Procedia CIRP*, 13th Global Conference on Sustainable Manufacturing – Decoupling Growth from Resource Use 40, 536–541. <https://doi.org/10.1016/j.procir.2016.01.129>
- Yilmaz, G., Qurban, K., Kaiser, J., McFarlane, D.C., 2023. Cost-effective digital transformation of SMEs through low-cost digital solutions, in: *Low-Cost Digital Solutions for Industrial Automation (LoDiSA 2023)*. Presented at the Low-Cost Digital Solutions for Industrial Automation (LoDiSA 2023), Institution of Engineering and Technology, Cambridge, UK, pp. 117–121. <https://doi.org/10.1049/icp.2023.1742>
- Yin, R.K., 1984. *Case Study Research: Design and Methods*. SAGE Publications.
- Zheng, T., Ardolino, M., Bacchetti, A., Perona, M., 2021. The applications of Industry 4.0 technologies in manufacturing context: a systematic literature review. *International Journal of Production Research* 59, 1922–1954. <https://doi.org/10.1080/00207543.2020.1824085>